



 osnovne informacije

- Regulator održava konstantan radni pritisak u sistemu.
- Opseg regulacije pritiska od 0,5 do 12 bar.
- Max pritisak na ulazu 16 bar.
- Regulator pritiska je modularne konstrukcije, što omogućava jednostavno kombinovanje sa drugim komponentama za pripremu vazduha.

 označavanje

**XOR 1/4 MINI**

Regulator pritiska sa  
 priključnim navojem G1/4

**XOR 1/2 MIDI**

Regulator pritiska sa  
 priključnim navojem G1/2

 Pneumatski simbol

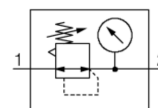

 tehničke informacije

	MINI	MIDI
Oznaka	XOR-1/4 MINI	XOR-1/2 MIDI
Radni fluid	Komprimovani vazduh	
Sastav kompleta	Regulator pritiska; manometar; vezni elementi	
Položaj montaže	U svakoj poziciji	
Opseg regulacije pritiska	0,5 do 12 bar	
Max histerezis	0,2 bar	
Max ulazni pritisak	16 bar	
Navoj za manometar	G1/8	G1/4
Priključni navoj	G1/4	G1/2
Protok vazduha	Prema dijagramima	



Dijagrami protoka

XOR 1/4 MINI

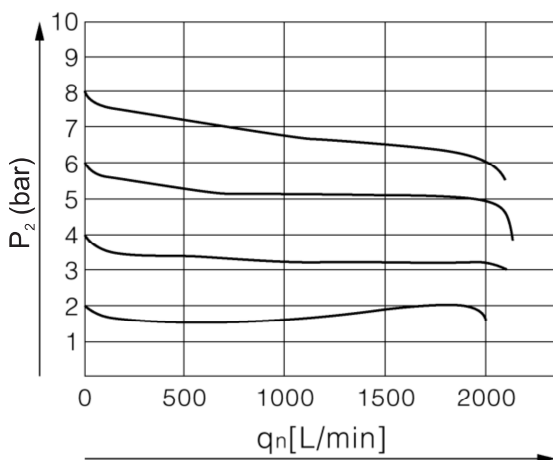

XOR 1/2 MIDI

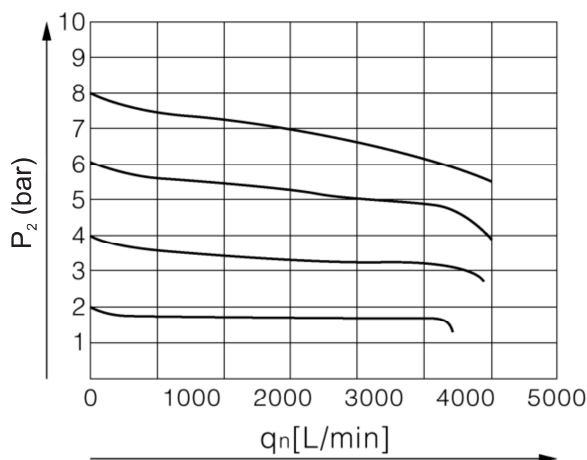

Struktura

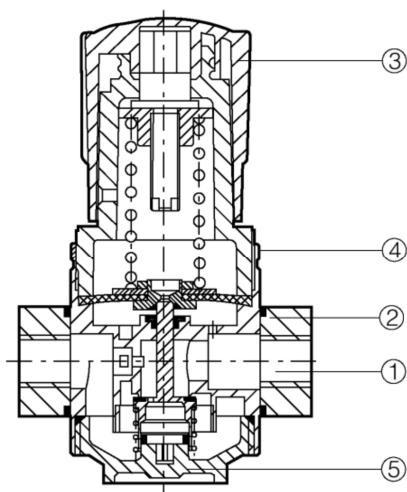

Poz.br	Naziv pozicije	Materijal
1	Kučičte	Aluminijumski odlivak
2	Priključna ploča	Aluminijumski odlivak
3	Glava za podešavanje	POM
4	Navrtka za vezu	Aluminijum
5	Donji poklopac	Aluminijumski odlivak
	Zaptivni komplet	NBR



crtež

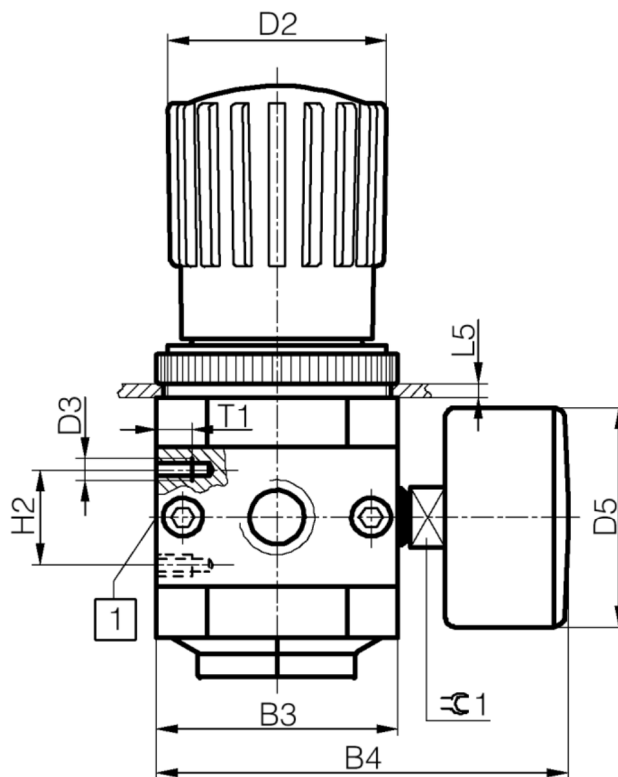
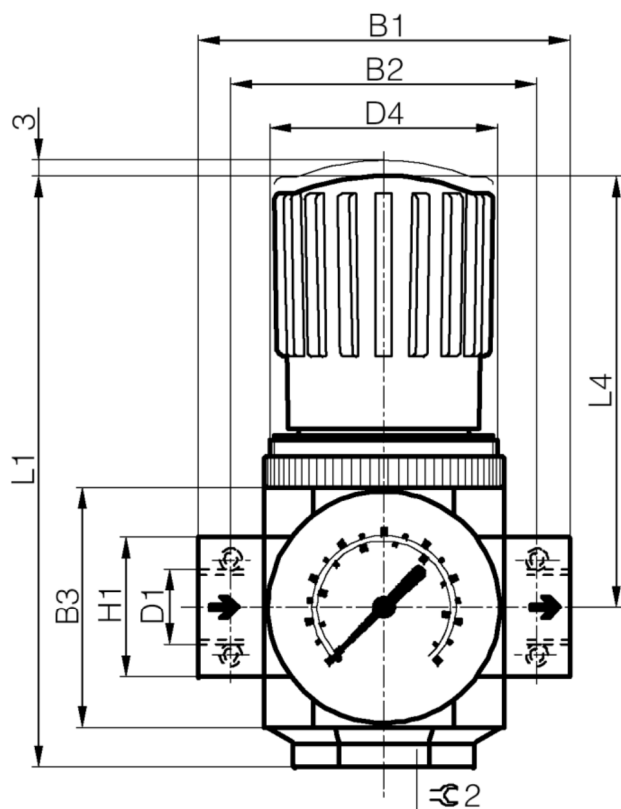

1 Drugo mesto za ugradnju manometra



dimenzije

	XOR-1/4 MINI	XOR-1/2 MIDI
B1	64	85
B2	52	70
B3	40	55
B4	76	95
D1	G1/4	G1/2
ØD2	31	50
D3	M4	M5
D4	M36x1.5	M52x1.5
ØD5	41	50
H1	20	32
H2	11	22

	XOR-1/4 MINI	XOR-1/2 MIDI
L1	94	135
L4	68	99
L5	3	5
L6	98	130
L7	60	60
T1	7	8
1	14	14
2	22	24